

1. 集油桶的搬运、堆高、称重于一身
 2. 带电子称重式，有置零、去皮、称重功能，精确度达到 $\pm 3\%$ 。
- Ergonomic solution for lifting, transporting, weighing and stacking drums;
 - With Scale, which can control pouring & measure capabilities, accuracy: $\pm 3\%$;

型号 Model		DT400A-1
额定负载 Rated load capacity	kg	400
净重 Net weight	kg	130
脚轮规格 Wheel Dimension	mm	$\varnothing 150 \times 50$
转弯半径 Turning Radius	mm	1300

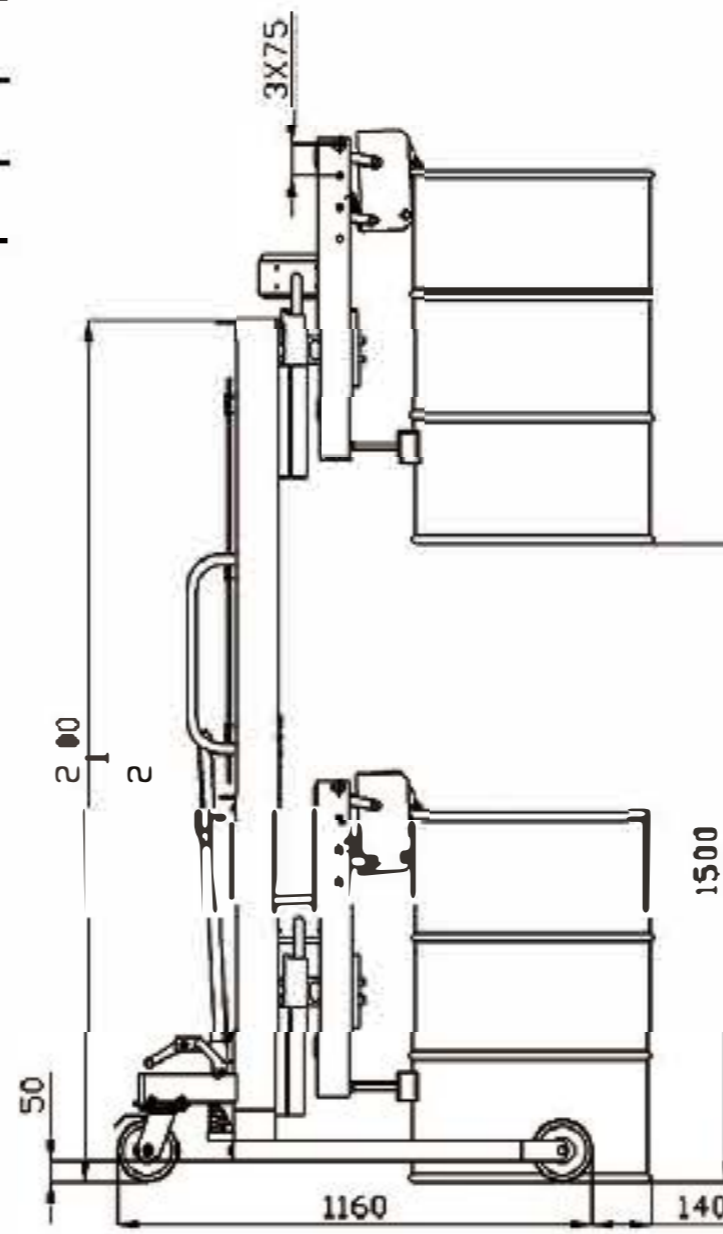
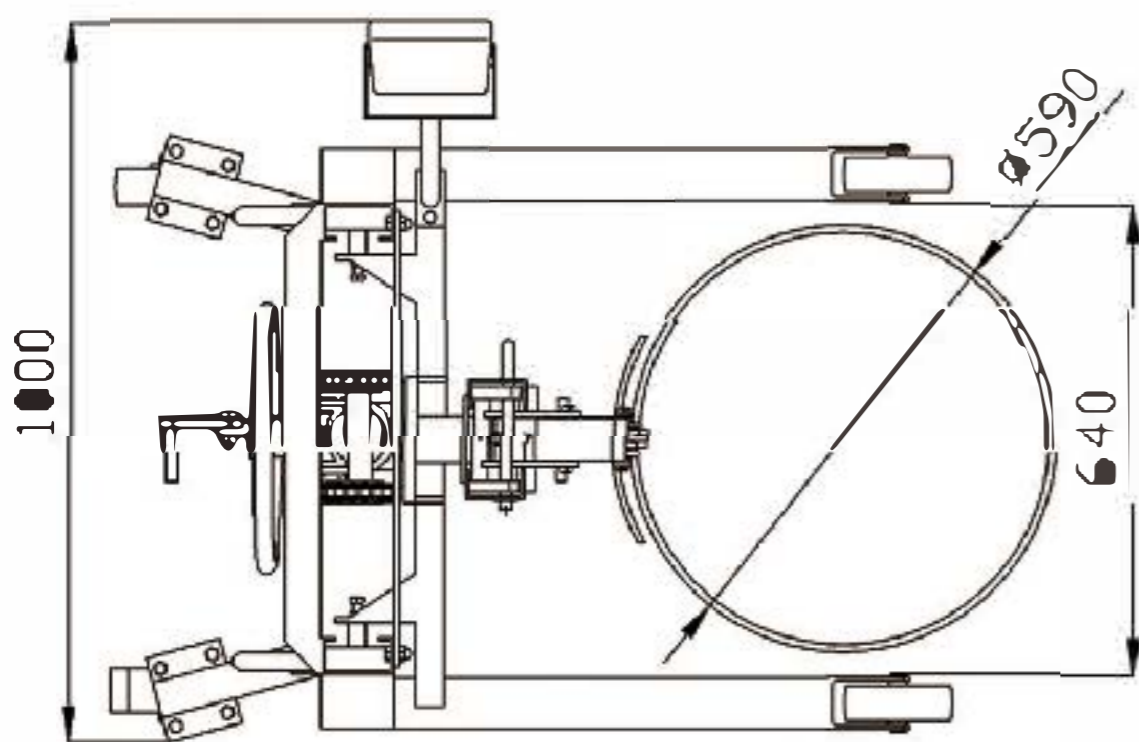

液压油桶翻转车

Portable Hydraulic Drum Dumpers

1. 独特的多功能：升高、搬运、翻转、倾倒、操作安全简单；
2. 特殊轧制工艺制造的 C 型门架，坚固安全。
3. 弓扣式和抱箍式相结合，适合各种钢制和塑料的桶，手摇 180 度旋转，可以把桶保持在任何角度。

- Multi-function of lifting, transporting, rotating, tilting and weighing drums;
- Special rolling technology manufactured C-shaped steel frame which is strong and safe;
- Combined Eagle-grip structure and Anchor ear structure together; is suitable for types of steel drums and plastic drums;
- Manually hand rotate drums 180 degree, and can keep drums at any angle;

型号 Model Hydraulic Drum Dumper		DA450-1
额定负载 Rated load capacity	kg	450
净重 Net weight	kg	185
脚轮规格 Caster dimension (Front/back)	mm	$\varnothing 150 \times 50$

